

O. H. WADE.
Belt-Shifting Apparatus.

No. 143,736.

Patented Oct. 14, 1873.

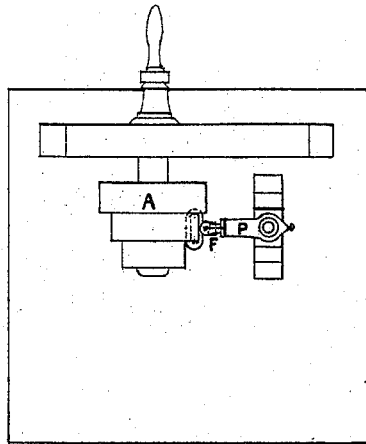

Fig. 1.

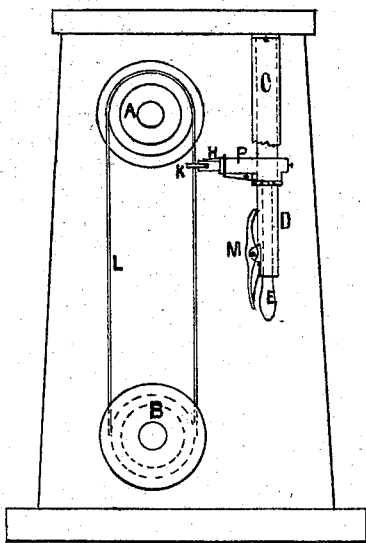

Fig. 2.

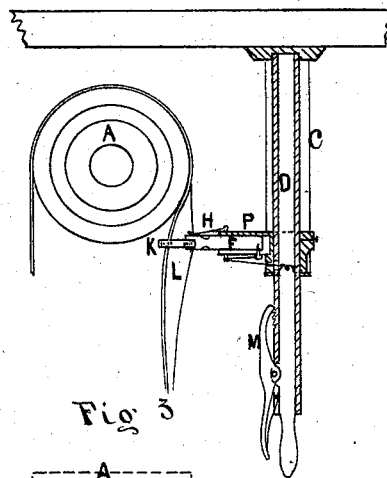

Fig. 3.

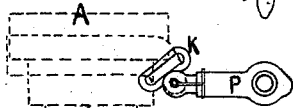

Fig. 4.

WITNESSES

Frankl. Parker
R. Evans

INVENTOR

Oliver H. Wade
Wm. Williams

UNITED STATES PATENT OFFICE.

OLIVER H. WADE, OF EAST BRIDGEWATER, MASSACHUSETTS.

IMPROVEMENT IN BELT-SHIFTING APPARATUS.

Specification forming part of Letters Patent No. **143,736**, dated October 14, 1873; application filed April 9, 1873.

To all whom it may concern:

Be it known that I, OLIVER H. WADE, of East Bridgewater, in the county of Plymouth and State of Massachusetts, have invented a certain new and useful Belt-Shifting Apparatus, of which the following is a specification:

The nature of my invention consists in arranging a device for shifting belts from one size pulley to another, or, as they are commonly designated, cone-pulleys. This I effect by the use of an adjustable belt-guard, in combination with a sliding rod that has a motion on its axis so that the guard may be brought as near to the pulley as desired in all directions, and, it being adjustable, will force the belt in the desired direction, and at the same time allow the belt to twist into position to readily go onto the next pulley. The object of this invention is to facilitate the operation of changing the belt when one of the cones is out of the immediate reach of the operator.

Figure 1 is a plan, showing my invention. Fig. 2 is an elevation of the same. Fig. 3 is a side elevation of a part of the same. Fig. 4 shows a part of the shifter in plan.

Let A and B represent two cone-pulleys, such as they use for a lathe, for instance, the cone A being hung to the ceiling or at a considerable elevation. L represents the belt which communicates power from one to the other. C is a bracket, to which I attach my belt-shifter. D is a hollow rod, suspended in such a manner as to be free to turn on its axis. Upon this rod I attach an arm, P, extending laterally from the rod D, as shown. Within this arm a sliding arm, F, is placed, and so arranged that it may be drawn out by the cord I, one end of which is attached to the inner end of F, and the other end to the sliding rod E, so that if E is drawn down F will be thrown out. H is a spring, which serves to draw F back into place. The rod E above referred to slides up and down in the rod D, as shown in Fig. 3, and also serves as a handle to turn the rod D and the arm P F. M is a pawl, attached to the rod E, and contacts with notches in the rod D so as to hold the rod E in any desired position. By drawing down the rod E the arm F is thrown out, as above referred to, the out-

ward motion of the arm F being equal to the downward motion of the rod E, as the two are connected by the string I. To the end of the arm F I attach the belt-guard K. This guard K is free to swing upon the arm F, and thus adapt itself to the natural twist of the belt, as shown in Figs. 3 and 4.

To use my belt-shifter I proceed as follows: When I wish to change from the larger pulley to a smaller one overhead, I have simply to turn the shifter so that the guard K will push against the belt, as indicated in Figs. 3 and 4, and force it from the larger toward the smaller pulley. This action, combined with the running of the belt, will soon throw it onto the smaller pulley, and leave the end of the belt loose, so that the operator can easily guide it with his hands onto the corresponding lower pulley.

To change the belt from a smaller pulley to a larger one overhead, the operator throws the belt off from the lower pulley, then turns the shifter so that the guard K will force the belt toward the larger pulley overhead, and thus cause it to run onto it.

The object of causing the arm F to project more or less at different times is so that it may accommodate itself to the different-size pulleys on the upper cone. Thus, in shifting the belt from one of the smaller to the next larger it is better that the arm F should be extended so that the guard K may be near to the pulley; but in case we go from the largest to the next smaller the arm F wants to be withdrawn, as shown in Fig. 4.

I claim as my invention—

1. The turning-rod D, in combination with the arm P and belt-guard K, operating substantially as described, and for the purpose set forth.

2. The combination of the rod D, the sliding rod E, arm F, and the guard K, operating substantially as described, and for the purpose set forth.

OLIVER H. WADE.

Witnesses:

FRANK G. PARKER,
WILLIAM EDSON.